

Sensor Tap – All-In-One

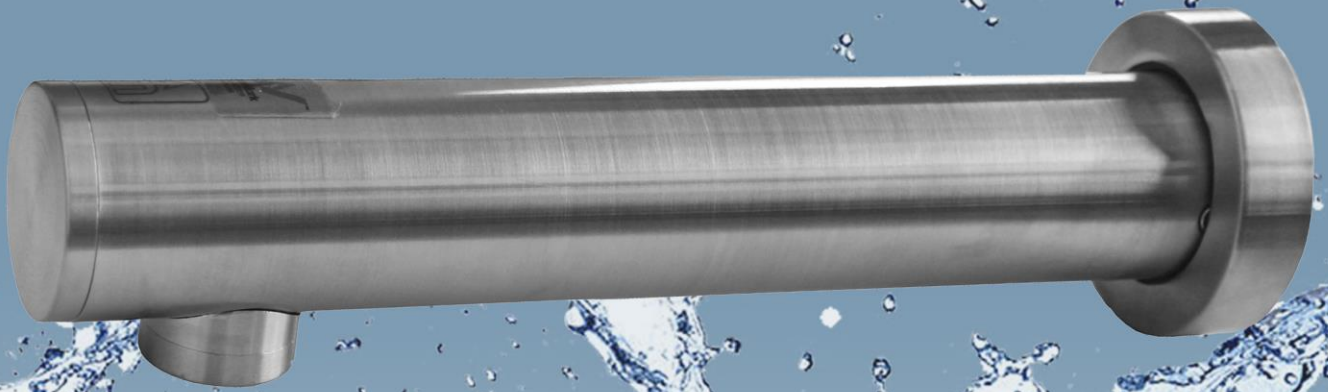

The more stars the more water efficient

WATER RATING
www.waterrating.gov.au

5.0 litres per minute

In accordance with AS/NZS 6400

Licence No. 1718
Mitchell Engineering Food
Equipment Pty Ltd

WaterMark
WM-022559
AS/NZS 3718

MEFE

CAT 673031

All-in-one – Stainless Steel Wall Mounted

Features

Up to 70% water saved
 Hygienic with zero cross contamination
 Touch free and accessible activation
 "Plug and play" digital infrared sensor technology
 Sensing range automatically adjusts to your environment
 Easy installation and supplied with everything required, replaces existing ½" connections
 Fully sealed all-in-one unit, no external components or wiring, 4 x AA batteries

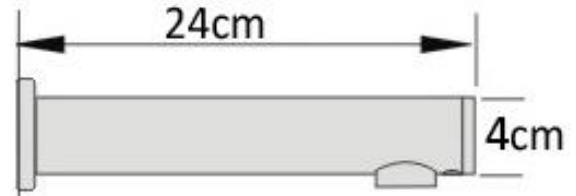

Dimensions

Spout – 24cm long
 Tap: 6 x 24 x 4cm, 0.7kg
 Boxed: 27 x 8 x 8cm, 0.8kg



Includes

All-in-one unit (solenoid valve, battery housing & brass housing)
 Instruction manual

Specifications

Wall Mounted
 Stainless Steel
 Fully sealed (all-in-one unit)
 Standard ½" Connection
 10cm Pre-set Sensing Range
 Water Pressure: 0.07-0.7Mpa

Available Finishes

-  CAT 673031 – Chrome Plated
-  CAT 673031B – Matte Black

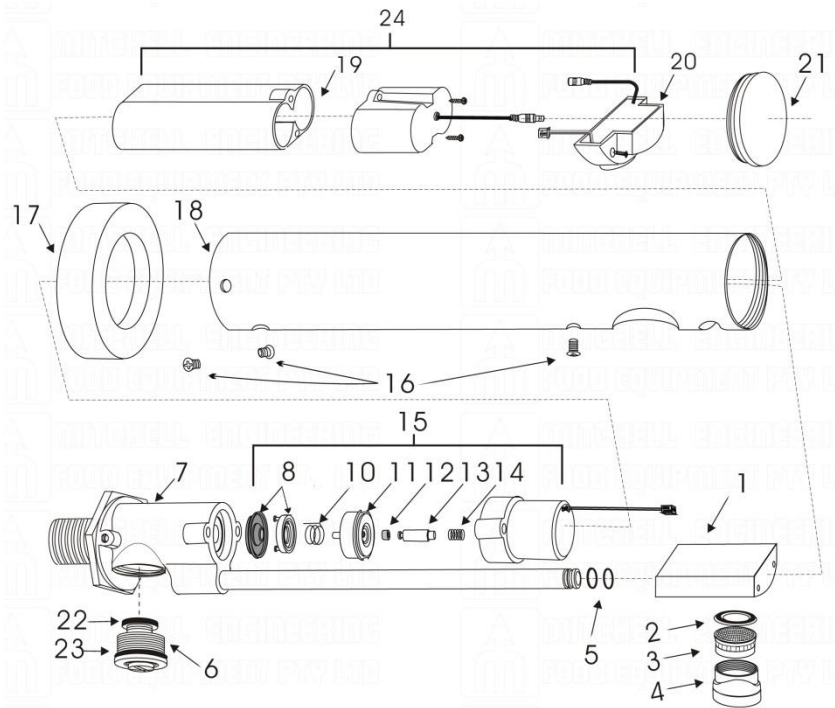

MEFE Sensor Taps are WaterMark certified and have been awarded 6 Stars, the highest WELS water efficiency rating. This signifies that our taps are eco-friendly and of the highest quality being AUS and NZ certified. Our range is DDA compliant when installed in accordance with AS 1428.1 2009.



1800 669 006
info@mefe.com.au www.mefe.com.au
 Tel: 07 3283 4536 Fax: 07 3283 4482

